

# **Kompakte Trennscheren PSC**



**P/A GmbH  
Mörikestrasse 30/2  
71636 Ludwigsburg**

**Tel.: 07141/974478-0  
Fax: 07141/974478-1  
e-mail: [info@pa.com](mailto:info@pa.com)  
[www.pa.com](http://www.pa.com)**

# Kompakte pneumatische Trennschere PSC

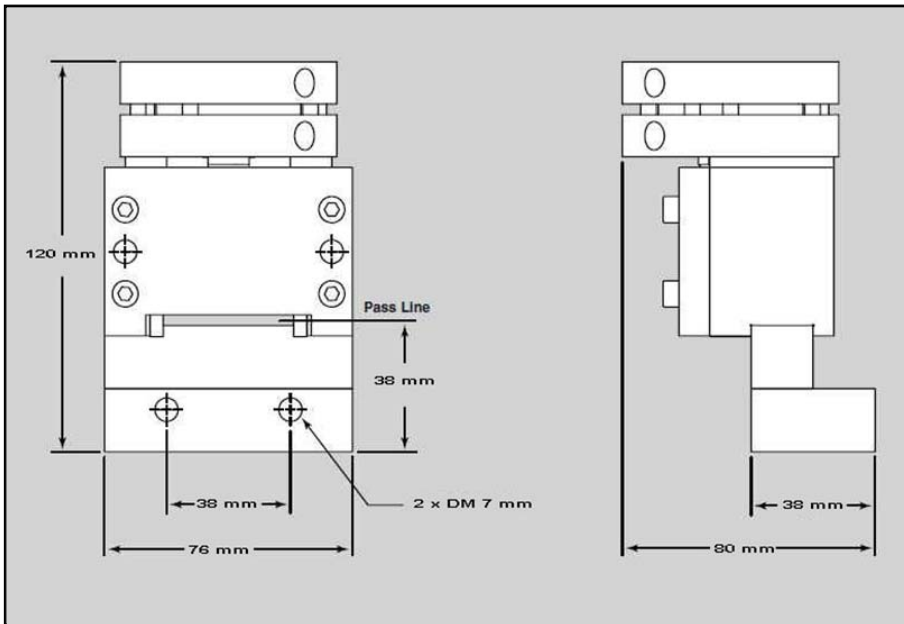

(PSC-38)

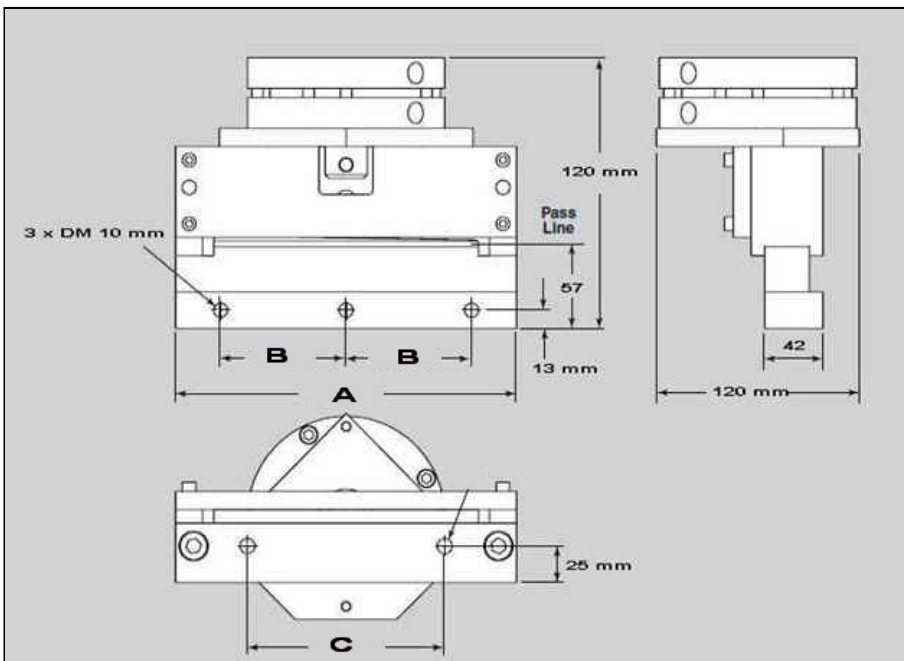

(PSC-75, PSC-125, PSC-175)

Technische Daten	PSC-38	PSC-75	PSC-75X	PSC-125	PSC-175
Max. Materialbreite	38 mm	75 mm	75 mm	125 mm	175 mm
Max. Dicke bei voller Breite Aluminium, Messing	0,4 mm	1,2 mm	2,0 mm	1,4 mm	1,4 mm
Stahl (400 N/mm <sup>2</sup> )	0,3 mm	0,7 mm	1,1 mm	0,7 mm	0,7 mm
Edelstahl	0,2 mm	0,6 mm	0,9 mm	0,6 mm	0,6 mm
Max. Schneidkraft bei 6,8 bar	0,8 KN	5,6 KN	12,3 KN	12,3 KN	12,3 KN
Max. Hubzahl unbelastet	100 1/min.	100 1/min.	100 1/min.	100 1/min.	100 1/min.
Durchmesser Luftzylinder	38 mm	100 mm	150 mm	150 mm	150 mm
Luftverbrauch bei Maximaler Hubzahl	1,4 L/Sek.	6,6 L/Sek.	11,8 L/Sek	11,8 L/Sek	11,8 L/Sek
Transportgewicht	3 Kg	12 Kg	13 Kg	15 Kg	17 Kg
Breite	76 mm	140 mm	140 mm	190 mm	240 mm
Höhe	120 mm	120 mm	120 mm	120 mm	120 mm
Tiefe	90 mm	120 mm	120 mm	120 mm	120 mm